

T200

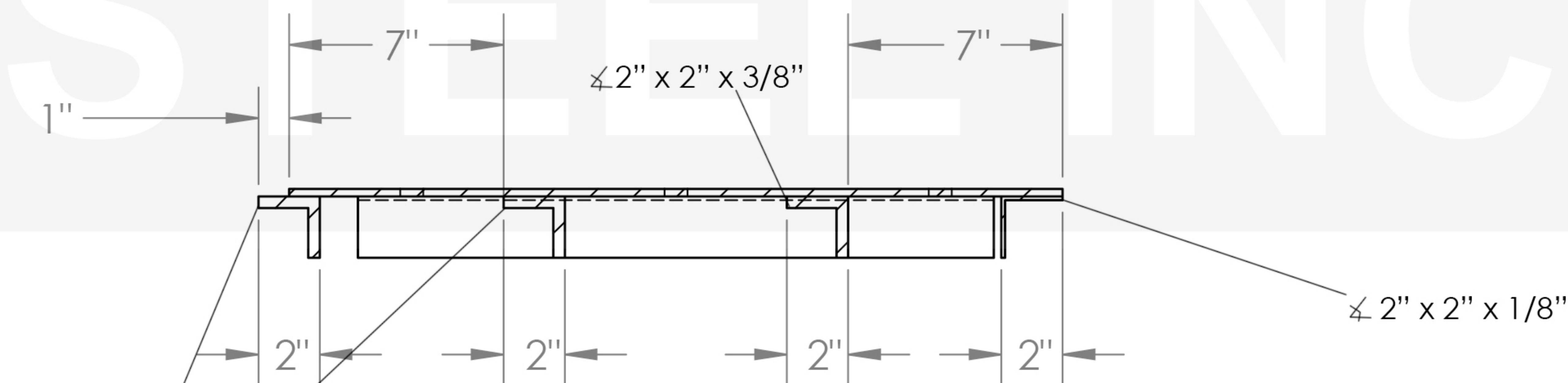
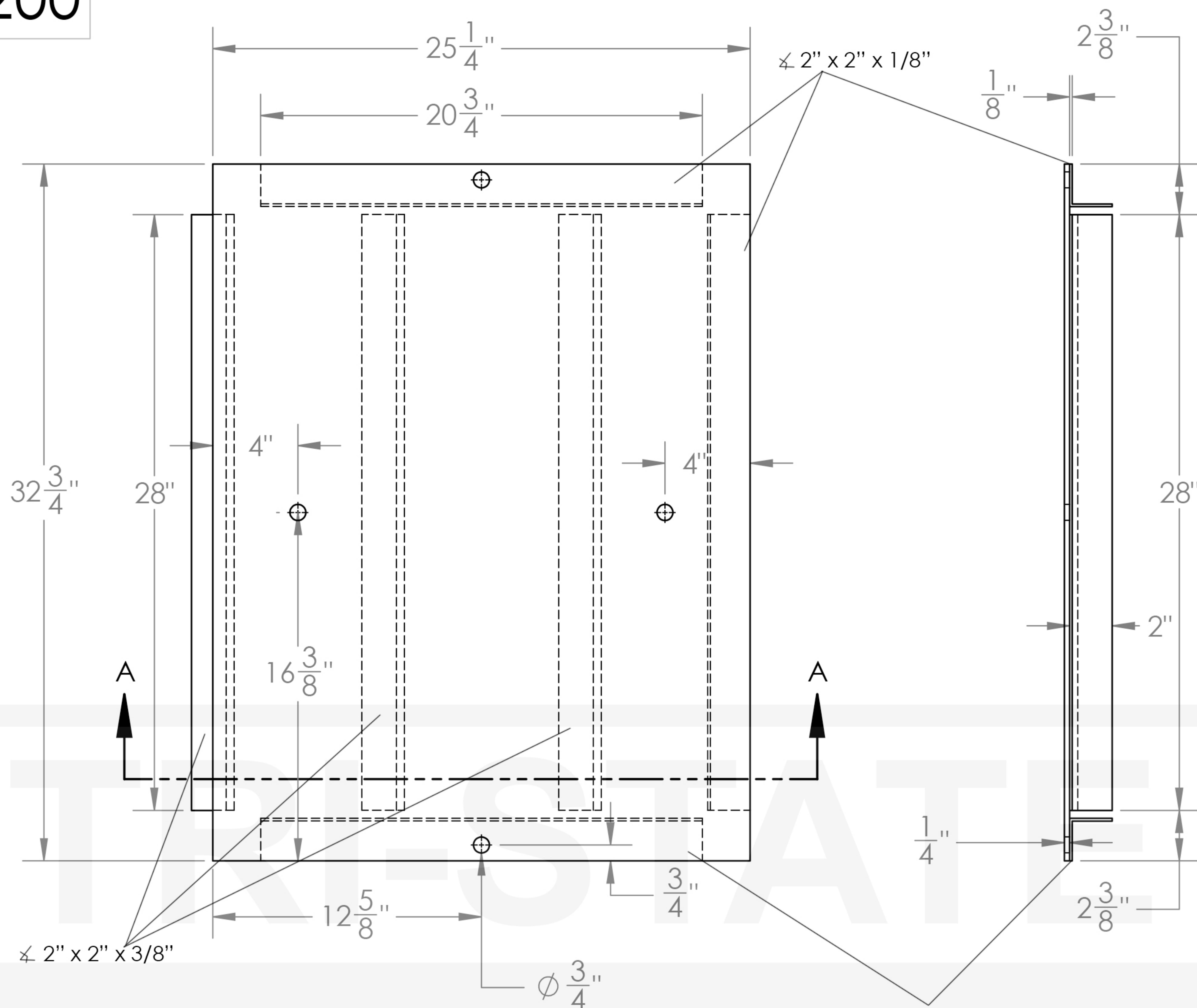

SECTION A-A

**TRI-STATE
STEEL INC.**

LID #1 ANGLE BAR SUPPORT LAYOUT

T200

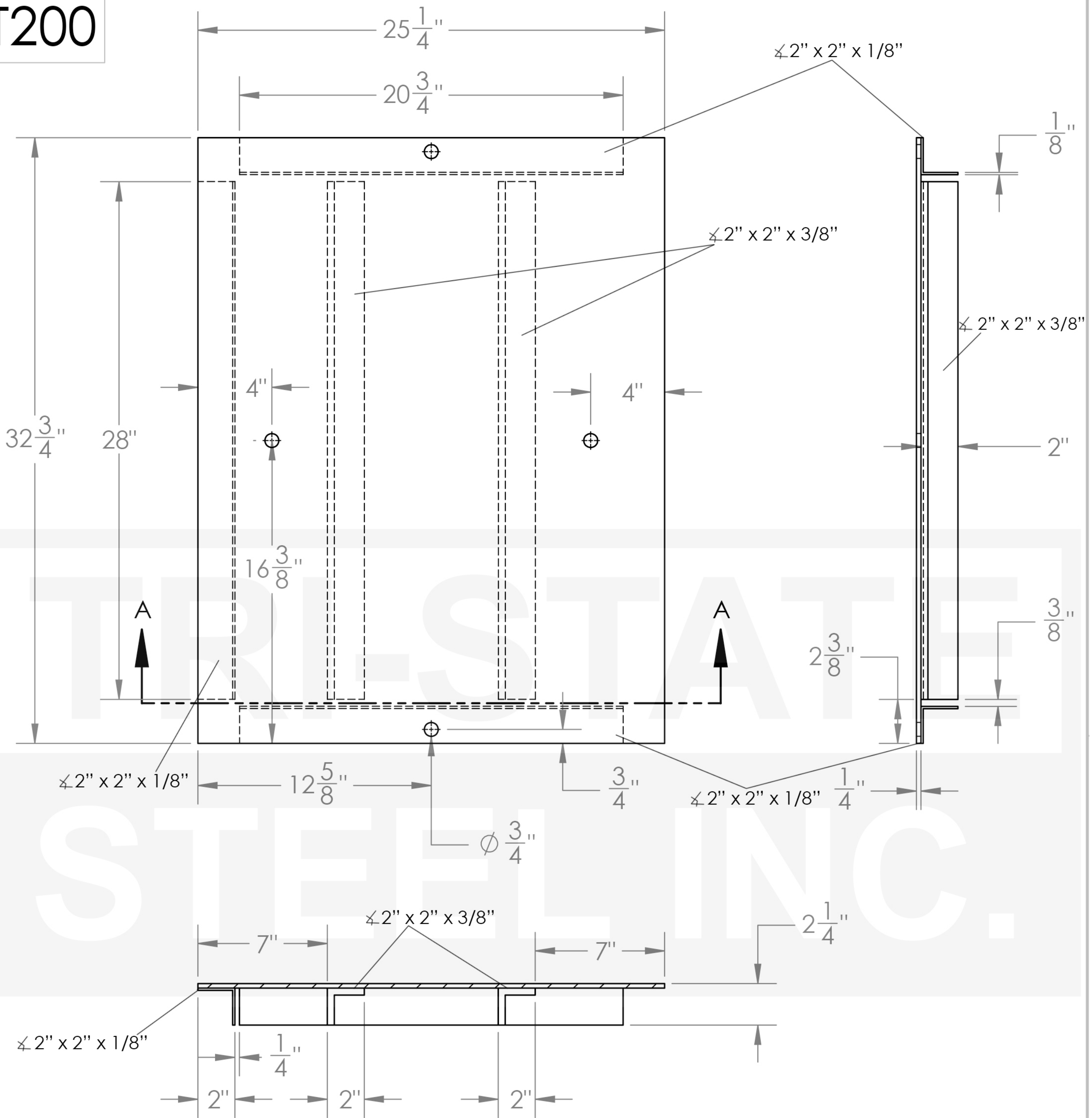

SECTION A-A

**TRI-STATE
STEEL INC.**

LID #2 ANGLE BAR SUPPORT LAYOUT